

POTOMAC RIVER



# Potomac Interceptor MH410-MH411 Repair

Community Meeting • June 11, 2026

# Potomac Interceptor

- 54 miles, constructed in 1960s
- 36" to 96" in diameter
- Serves Fairfax & Loudoun Counties, Town of Vienna, Herndon, and Dulles Airport in VA and Montgomery County, MD
- 84 Jurisdictional Connections
- 60 million gallons per day (MGD) flows to the Blue Plains at downstream end

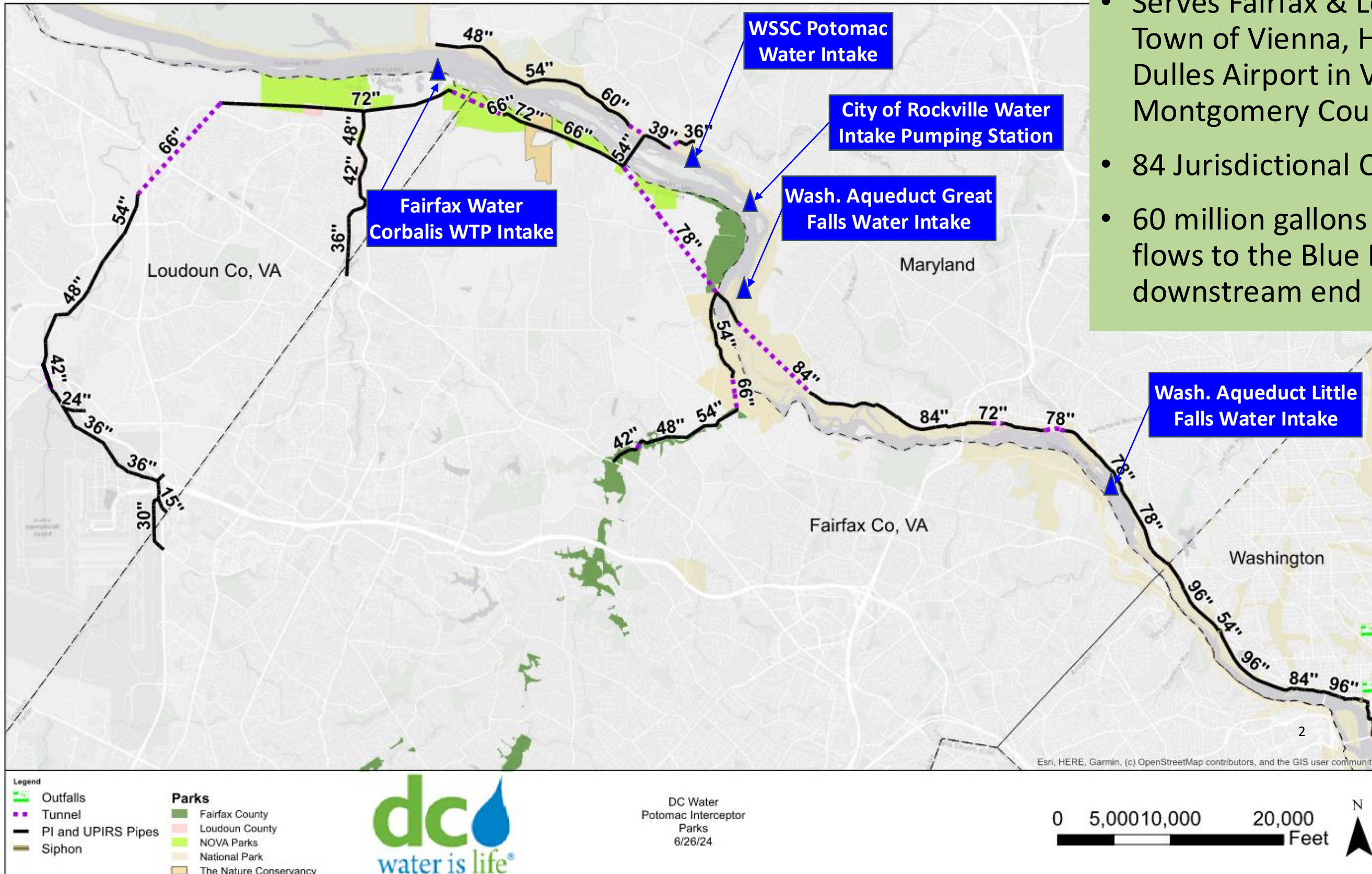

# Inspections – More Than 99% Complete

- **DC Water has inspected more than 99% of the entire 54-mile Potomac Interceptor**
  - Inspection techniques completed to date
    - CCTV – video cameras inside the pipe
    - Multi Sensor Inspection (MSI) – measures pipe condition and wall loss
      - Laser above water
      - Sonar below water
    - Drone inspections of hard-to-reach sections
    - Surface pipe walks along the alignment
    - Testing Ground Penetrating Radar (boulders)
  - Repair projects are moving forward on an accelerated basis wherever inspections found issues
- Allows estimate of internal pipe dimension to compare against record drawings
  - Allows estimate of pipe wall thickness loss due to corrosion

# Projects Identified Based on Enhanced Inspections

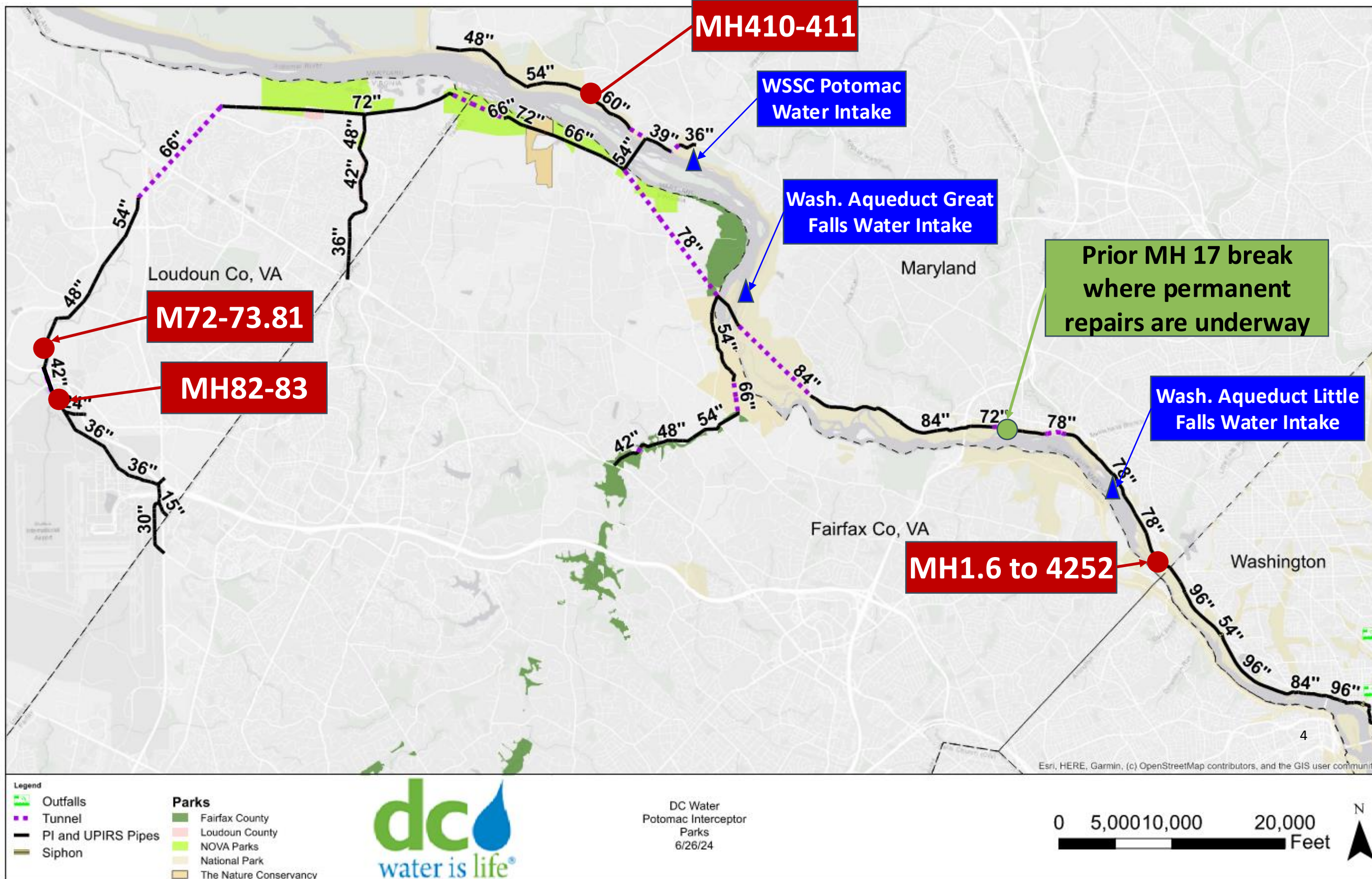

# MH410-411 vs. the January Collapse

| Factor                            | MH410-411 Segment  | January Collapse Site   |
|-----------------------------------|--|---|
| <p><b>Backfill over pipe</b></p>  | <p>No boulders <u>at stream crossing</u> where pipe is shallow</p>                               | <ul style="list-style-type: none"> <li>• Boulders in the backfill directly on top of the pipe</li> </ul>          |
| <p><b>Concrete protection</b></p> | <p>Extra layer of concrete reinforcement protects the pipe</p>                                   | <ul style="list-style-type: none"> <li>• No extra concrete reinforcement layer at the point of failure</li> </ul> |
| <p><b>Surface impact</b></p>      | <p>No sinkhole – identified proactively through inspections, with repairs planned in advance</p> | <ul style="list-style-type: none"> <li>• Sinkhole formed at the surface</li> </ul>                                |

# MH410-411 Project Pipe and Conditions

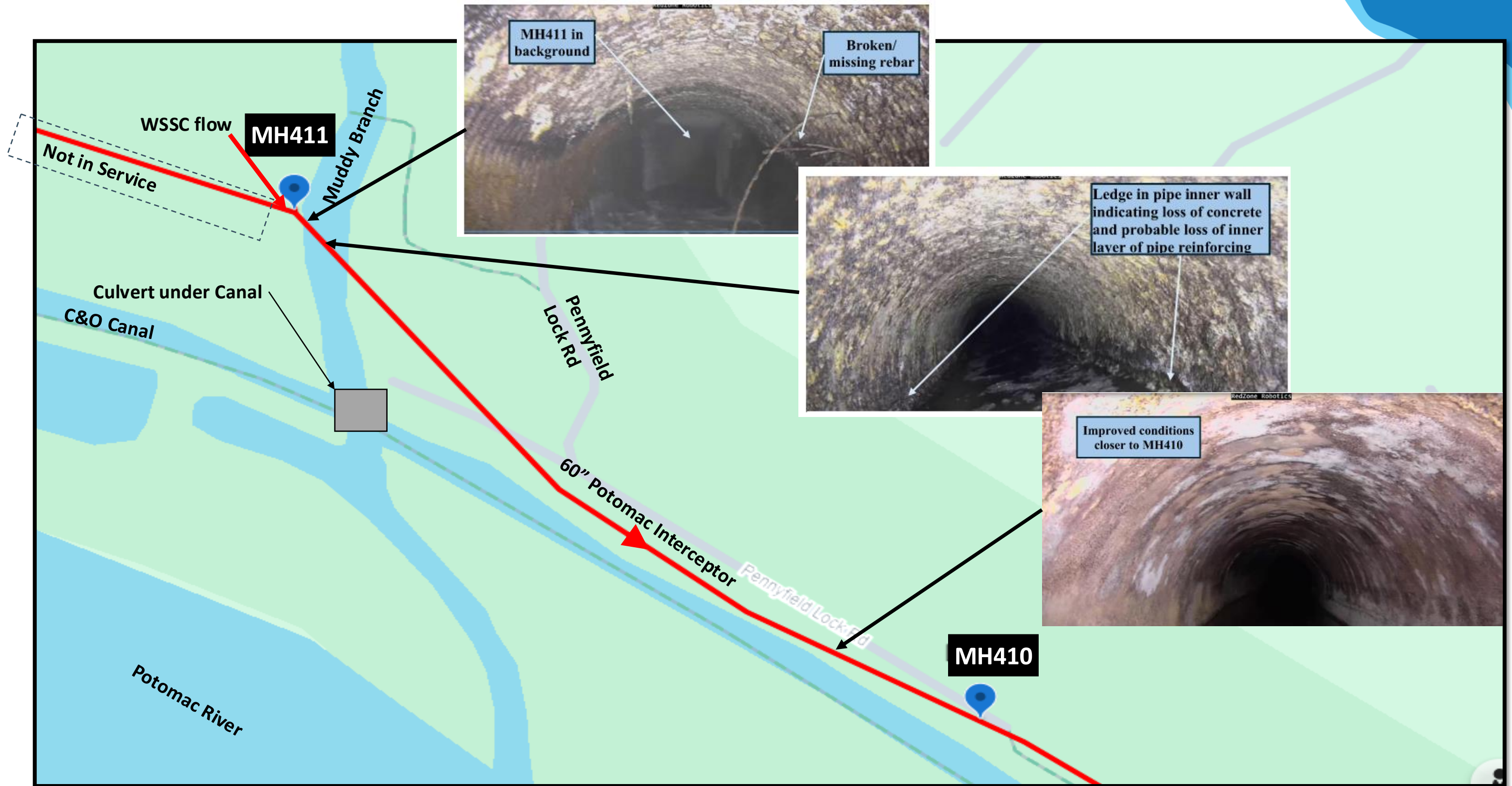



# Repair Plan

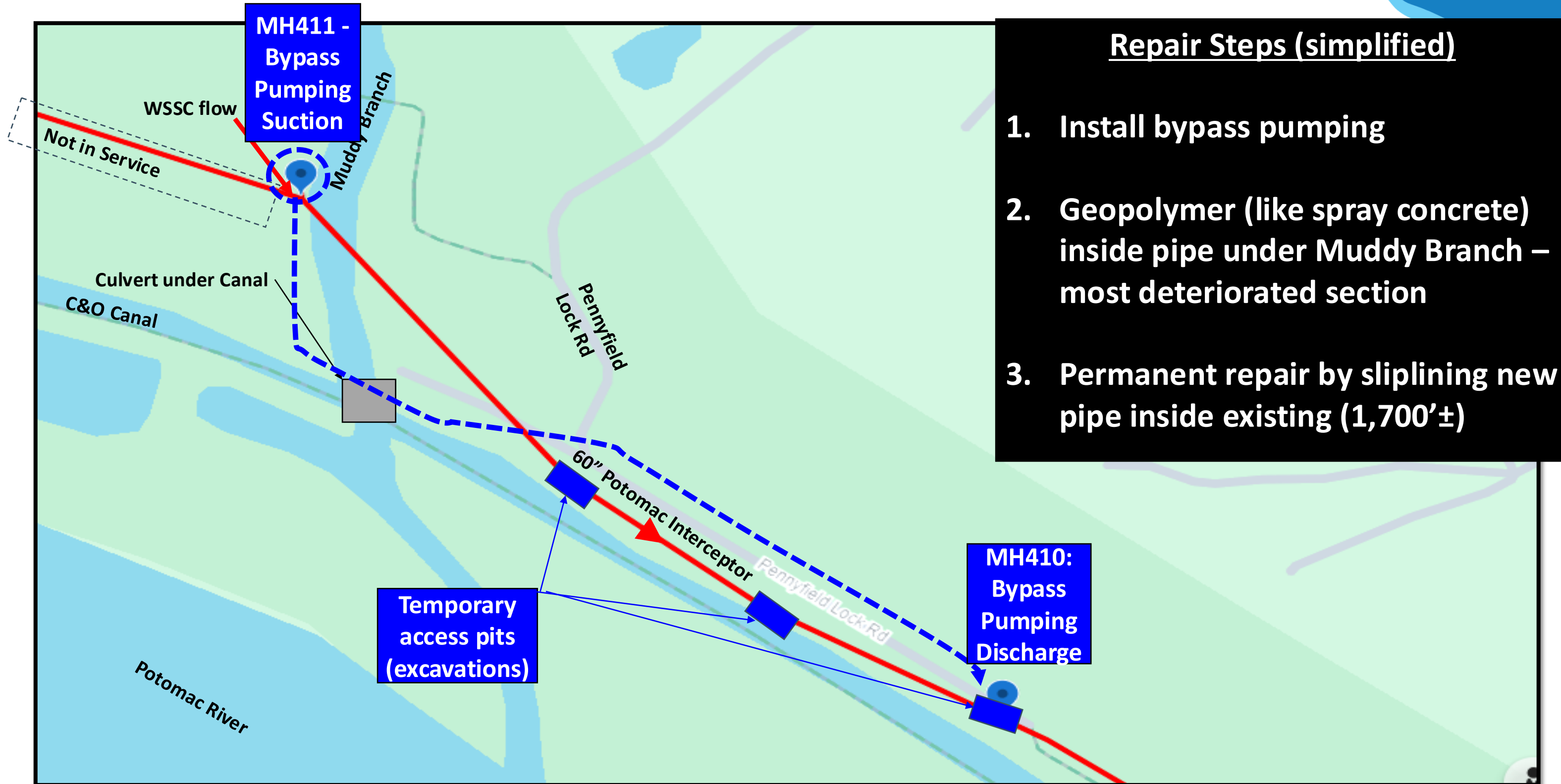

- ### Repair Steps (simplified)
1. Install bypass pumping
  2. Geopolymer (like spray concrete) inside pipe under Muddy Branch – most deteriorated section
  3. Permanent repair by sliplining new pipe inside existing (1,700'±)

# Anticipated Schedule

- Mobilization – week of June 15
- Bypass installation – through third week of July
- Geopolymer installation – August
- Slip-lining – September
- Substantial Completion – October



# What to Expect During Construction

- **Odors**

- Temporary sewer odors are possible near work areas when the pipe is opened and during bypass pumping
- Odors may be more noticeable during high summer temperatures – DC Water will monitor and apply odor control measures

- **Construction Equipment and Noise**

- Excavators, pumps, generators, and trucks at temporary access pits near Pennyfield Lock Rd
- Bypass pumps will run continuously (24/7) once operational – sound attenuation will be used

- **Traffic and Access**

- Periodic truck traffic on Pennyfield Lock Rd; signage and flaggers as needed
- Temporary impacts to trail and boat ramp access at Pennyfield Conservation Area – coordinated with NPS

- **How to Reach Us**

- Report odors or concerns: DC Water 24-Hour Command Center at 202-612-3400 and project web page updates

# Interim Risk Mitigation Actions

- Daily surface pipe walks by DC Water operations staff
- Flow meter installed at MH 410 – allows real-time notifications of any changed conditions necessitating a change in posture
- Advance positioning of materials and equipment in the event of unexpected deterioration
  - Position excavator, trench boxes, street plates, stone, clean fill, plastic sheeting etc.
- Establish coordination and lines of communication with other stakeholders in the event of a change in posture:
  - WSSC
  - City of Rockville
  - Washington Aqueduct
  - Fairfax Water

# Drinking Water is Not Impacted

Visit [wsscwater.com](http://wsscwater.com)  
or email  
[OEM@wsscwater.com](mailto:OEM@wsscwater.com)  
for more  
information



# Communications and Stakeholder Engagement

## Key Engagement Activities

### Public Information & Project Updates

- Regular updates through the Potomac Interceptor website
- Information shared with partner agencies and key stakeholders
- Project milestones, construction activities, and mitigation efforts communicated proactively

### Community Outreach

- Social media, Nextdoor, HOA and neighborhood listservs
- Community meetings and local events
- Targeted notifications, including direct mail and door hangers, as needed



# Communications and Stakeholder Engagement

## Key Engagement Activities

### Stakeholder Engagement

- Briefings for elected officials, community organizations, environmental groups, and other interested stakeholders
- Ongoing coordination with local governments, regulatory agencies, drinking water providers, and regional partners

### Media Relations

- Proactive engagement with local and regional media
- Timely responses to media inquiries and project developments

### Emergency Communications

- Notification protocols and stakeholder contact lists to support rapid communications should conditions change



# Emergency Preparedness and Response

- Conduct weekly Unified Coordination Group and agency briefing to provide updates Potomac Interceptor emergency repairs.
- Contact list of jurisdictions and response partners has been established for timely and effective notifications and situational awareness.
- In the event of an incident, DC Water will activate its Type 3 Incident Management Team and request coordinated response efforts with impacted local, state, and regional partners.

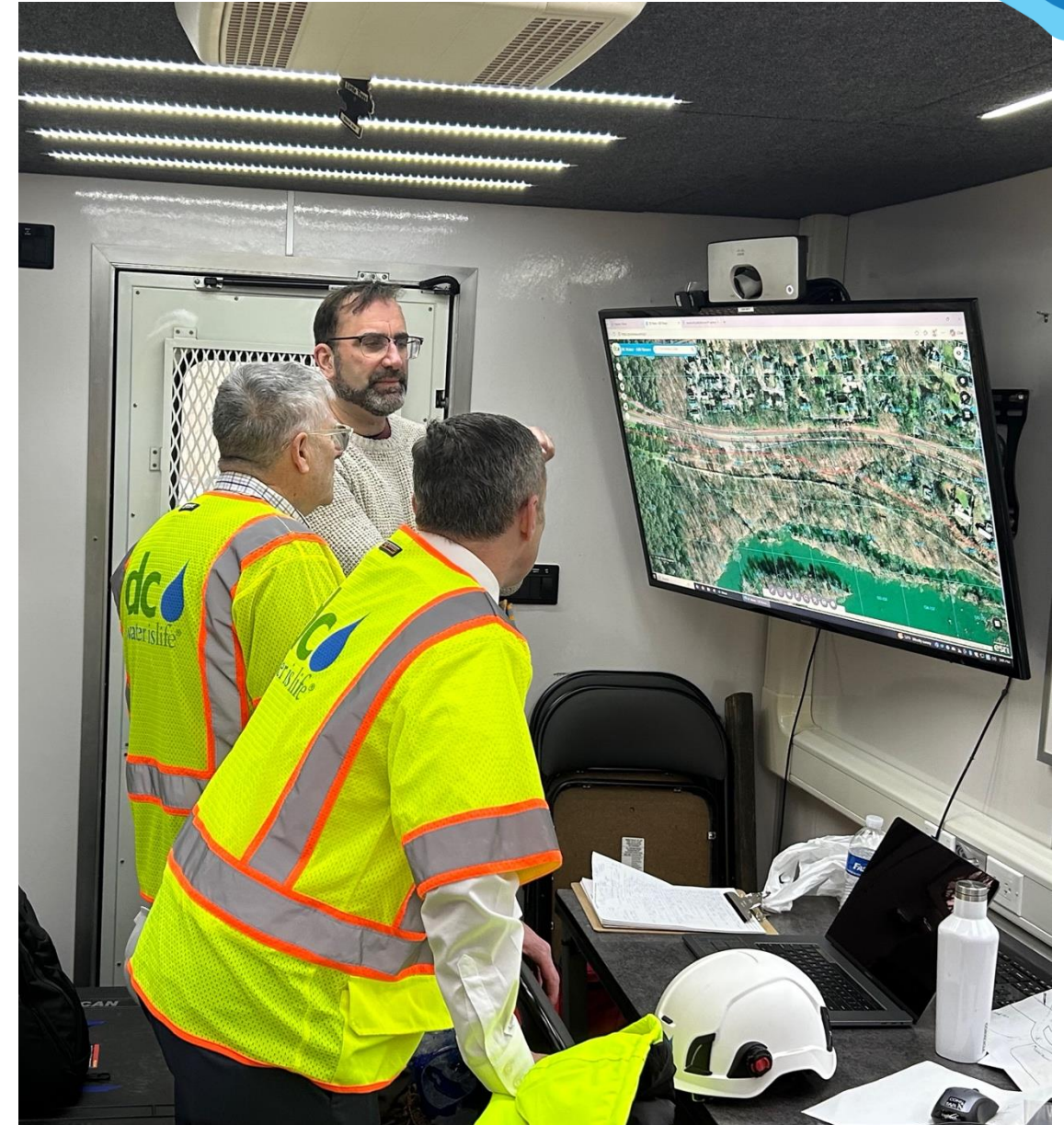

# Questions?

- Please look for project updates on our website at [dcwater.com/potomacinterceptor](https://dcwater.com/potomacinterceptor)
- Contact us with any questions at [potomacinterceptor@dcwater.com](mailto:potomacinterceptor@dcwater.com)
- Thank you to our partners for helping move this project forward quickly

# Extra Slides

# Record Drawing

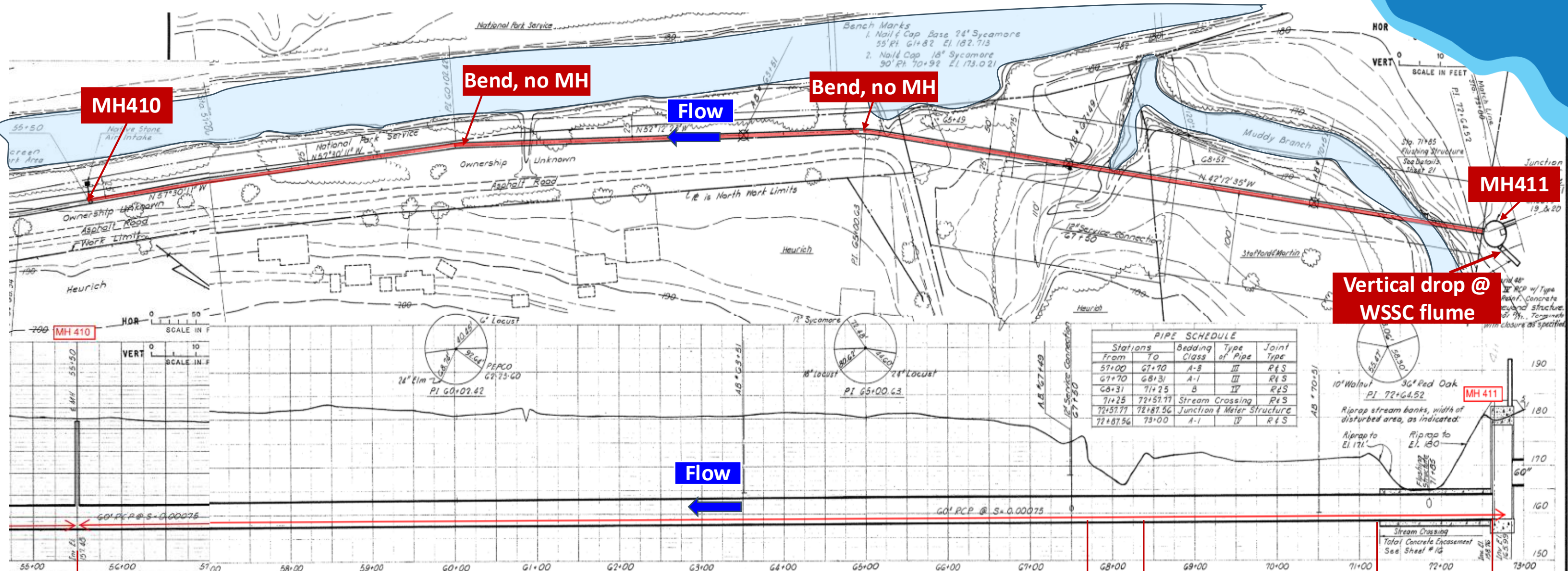

| PIPE SCHEDULE |             |                            |              |            |
|---------------|-------------|----------------------------|--------------|------------|
| Stations From | Stations To | Bedding Class              | Type of Pipe | Joint Type |
| 59+00         | 67+70       | A-3                        | III          | RFS        |
| 67+70         | 68+31       | A-1                        | III          | RFS        |
| 68+31         | 71+25       | B                          | IV           | RFS        |
| 71+25         | 72+58.77    | Stream Crossing            |              | RFS        |
| 72+58.77      | 72+81.56    | Junction & Meter Structure |              |            |
| 72+81.56      | 73+00       | A-1                        | IV           | RFS        |

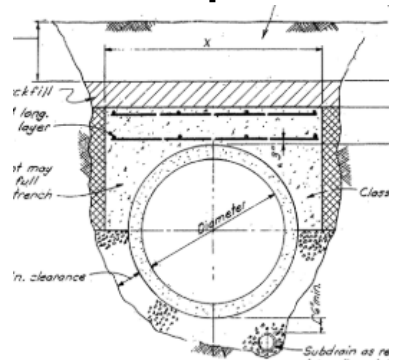

**A-3 : 2 layers #7 @ 8"**

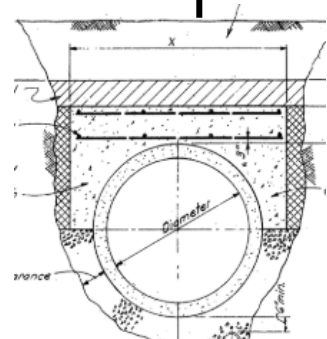

**A-1: no reinforcing**

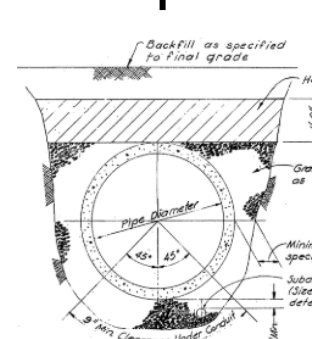

**Class B**

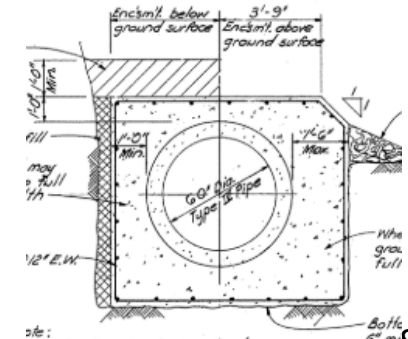

**Encasement**

# Multi-Sensor (MSI) Inspection

MSI data is irregular due to turbulence at drop and values beyond pipe thickness are not possible. Data indicates significant wall loss consistent with CCTV.

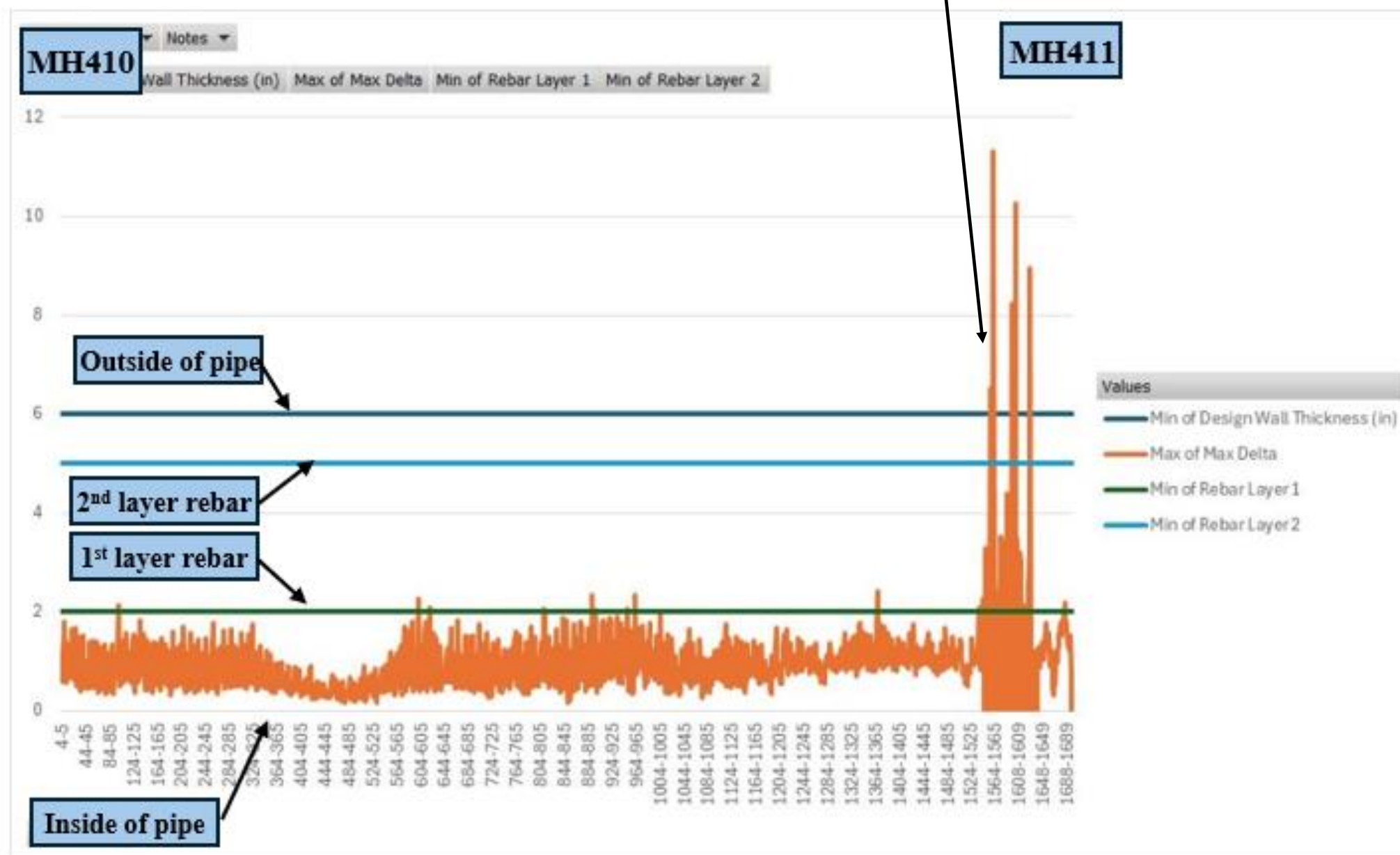

# MH410-411 Schedule



| PI Emergency/High Priority M410 to MH411    | 5/18 | 5/25 | 6/1 | 6/8 | 6/15 | 6/22 | 6/29 | 7/6 | 7/13 | 7/20 | 7/27 | 8/3 | 8/10 | 8/17 | 8/24 | 8/31 | 9/7 | 9/14 | 9/21 | 9/28 | 10/5 | 10/12 | 10/19 |  |
|---|------|------|-----|-----|------|------|------|-----|------|------|------|-----|------|------|------|------|-----|------|------|------|------|-------|-------|--|
| <b>Construction</b>                         |      |      |     |     |      |      |      |     |      |      |      |     |      |      |      |      |     |      |      |      |      |       |       |  |
| Mobilize                                    |      |      |     | 1   |      |      |      |     |      |      |      |     |      |      |      |      |     |      |      |      |      |       |       |  |
| Provide Access Path for Bypass              |      |      |     |     | 1    | 2    | 3    |     |      |      |      |     |      |      |      |      |     |      |      |      |      |       |       |  |
| Install Bypass Pipe                         |      |      |     |     |      |      |      | 1   | 2    | 3    | 4    |     |      |      |      |      |     |      |      |      |      |       |       |  |
| Install Geo-Polymer for Encasement Section  |      |      |     |     |      |      |      |     |      |      |      | 1   | 2    |      |      |      |     |      |      |      |      |       |       |  |
| Excavation for Sending Pit #1               |      |      |     |     |      |      |      | 1   | 2    |      |      |     |      |      |      |      |     |      |      |      |      |       |       |  |
| Excavation for Sending Pit #2               |      |      |     |     |      |      |      |     |      | 1    | 2    |     |      |      |      |      |     |      |      |      |      |       |       |  |
| Excavation for Receiving Pit #1             |      |      |     |     |      |      |      |     |      |      |      | 1   |      |      |      |      |     |      |      |      |      |       |       |  |
| Excavation for Receiving Pit #2             |      |      |     |     |      |      |      |     |      |      |      |     | 1    |      |      |      |     |      |      |      |      |       |       |  |
| Excavation for 12" Service Connection Pit   |      |      |     |     |      |      |      |     |      |      |      |     |      | 1    |      |      |     |      |      |      |      |       |       |  |
| Slip Line Run #1                            |      |      |     |     |      |      |      |     |      |      |      |     |      |      | 1    |      |     |      |      |      |      |       |       |  |
| Slip Line Run #2                            |      |      |     |     |      |      |      |     |      |      |      |     |      |      |      | 1    |     |      |      |      |      |       |       |  |
| Slip Line Run #3                            |      |      |     |     |      |      |      |     |      |      |      |     |      |      |      |      | 1   |      |      |      |      |       |       |  |
| Install Bend at Sending Pit #1 and Backfill |      |      |     |     |      |      |      |     |      |      |      |     |      |      |      |      |     | 1    |      |      |      |       |       |  |
| Install Bend at Sending Pit #2 and Backfill |      |      |     |     |      |      |      |     |      |      |      |     |      |      |      |      |     |      |      | 1    |      |       |       |  |

POTOMAC INTERCEPTOR – MH410-MH411 REPAIR





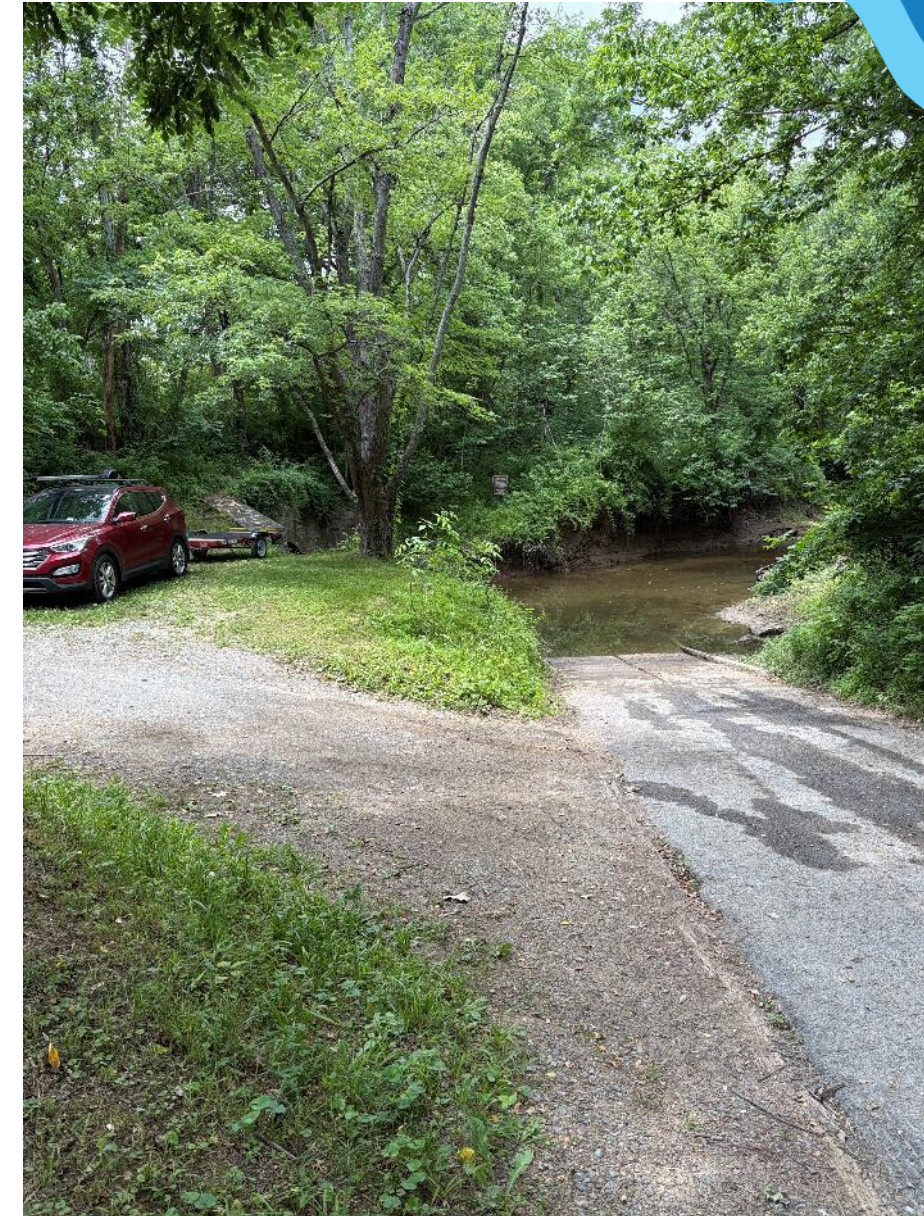
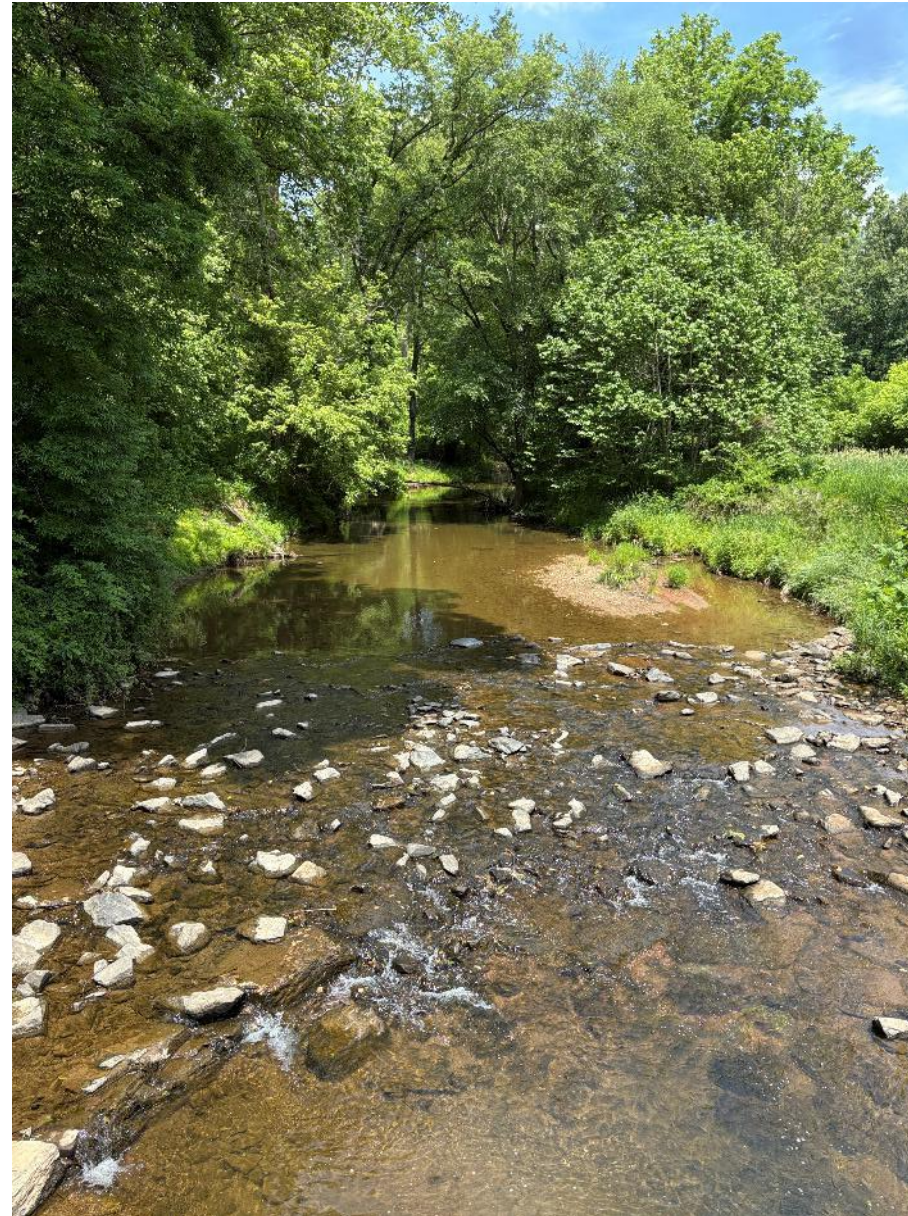

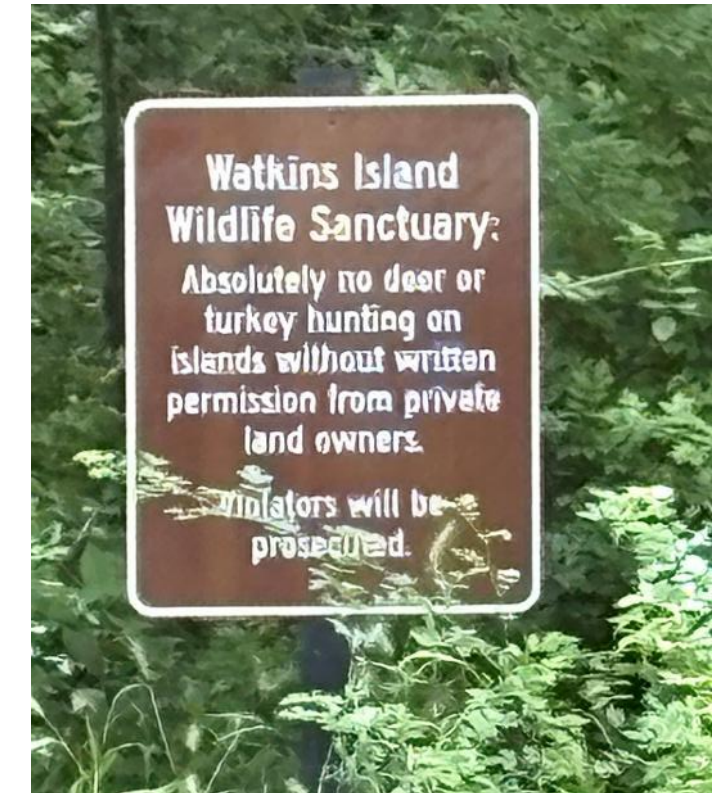

POTOMAC INTERCEPTOR – MH410-MH411 REPAIR



**MH410**